

Accuphase

DIGITAL FREQUENCY DIVIDING NETWORK

DF-45

- Channel divider units with high-speed DSP for fully digital signal processing
- Equipped for 4-channel (4-way) system configuration
- 59 selectable cutoff frequency points
- Highly accurate 96 dB/oct attenuation slope
- Time alignment function allows delay time setting in 1-cm steps
- Delay compensator offsets signal delays in filter circuitry
- Further refined MDS++ D/A converter
- Digital input possible in conjunction with DC-330





Multi-channel divider with fully digital signal processing – High-speed 40-bit floating point DSP provides the processing power for four channel units supplied in standard configuration. Choice of 59 cutoff frequency points ensures total flexibility. Highly accurate digital filters enable 96 dB/octave slope characteristics. Time alignment function adjustable in 1-cm steps, plus delay compensator for offsetting filter circuit delays ensure superb spatial accuracy. HS-Link capability provides SA-CD support.

Multi-amplification is regarded as the pinnacle of the audio world. The term refers to dividing the musical spectrum into several distinct bands and handling each of these using a dedicated power amplifier and directly connected speaker unit. When configured and adjusted properly, such a system can achieve sound reproduction on a scale that is not possible by any other means. Sonic definition and spatial imaging can be optimized by the user to obtain exactly the desired result. Configuring a multi-amplified system affords truly one of the greatest pleasures of audio.

The Digital Frequency Dividing Network DF-45 represents a further evolution of the model DF-35. Only the latest digital technology is employed throughout, and all internal signal processing occurs fully in the digital domain. High-speed 40-bit floating point DSP chips allow super-precise high-order filtering with a slope of 96 dB/octave. This in turn enables the digital input to handle sources up to SA-CD quality. In addition, balanced and unbalanced analog inputs are also provided, and the unit comes as a 4-channel device (for 4-way amplification) in its standard configuration. Each channel in the DF-45 is handled by a dedicated unit. A full array of functions including frequency dividing filters (low-pass, band-pass, high-pass), attenuation slope characteristics, delay and delay compensator function, level control, and phase switching are implemented in the digital domain. To store parameter settings for various scenarios, five memory positions are provided.

The DF-45 allows the user to select cutoff frequency settings for adjacent bands from 59 choices, plus six different attenuation slope settings (max. 96 dB/oct). This unprecedented flexibility makes it possible to elicit optimum performance from every speaker unit, achieving a smooth transition between bands and ensuring exactly the desired overall energy balance. A high-quality multi-amp system built with the DF-45 will sound its very best.

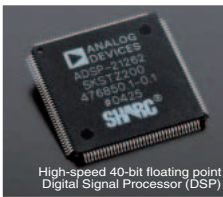

High-speed 40-bit floating point Digital Signal Processor (DSP)

Channel dividers based on fully digital signal processing

The central task of a multi-amp system is of course the division of the frequency spectrum into multiple bands or channels. The channel dividers in the DF-45 feature an impressive array of sophisticated digital technology based on a DSP chip with amazing power. The high-speed 40-bit floating point design of this device makes it possible to implement all filtering and delay functions as well as phase and level control in fully digital form. With minimal temperature drift and excellent long-term stability, this ensures filtering performance of the highest order.

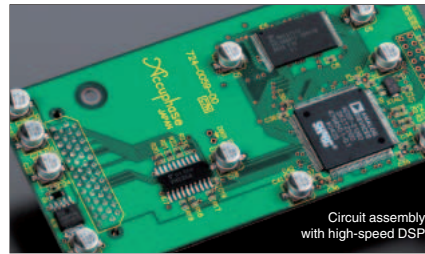

Circuit assembly with high-speed DSP

High-speed 40-bit floating point DSP assures precision digital filtering

As a crucial circuit element, the digital filter is configured with a high-speed 40-bit DSP that has a 32-bit mantissa and 8-bit exponent section. The floating point principle enhances calculation accuracy and results in dramatically improved dynamic range. This allows the implementation of extremely steep filter slopes of up to 96 dB/octave.

59 selectable cutoff frequency points

Filter frequency points can be set over the range from 31.5 Hz to 22.4 kHz in 1/6-octave intervals.

In addition, 10, 20, and 290 Hz points are also provided, resulting in a total of 59 points. Each divider unit is fully flexible and allows free selection of the lower and upper cutoff frequency, for configuration as a low-pass, bandpass, or high-pass filter.

Six filter slope characteristics up to 96 dB/octave

The filter attenuation characteristics can be set to 6 dB/octave, 12 dB/octave, 18 dB/octave, 24 dB/octave, 48 dB/octave, or 96 dB/octave. Within each unit, separate settings for lower and upper slope are possible, resulting in a wide variety of combinations.

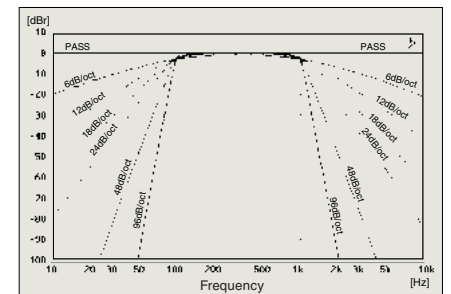

Fig. 2 Divider unit slope characteristics (bandpass filter) [Cutoff frequency setting 100 Hz for lower and 1 kHz for upper range]

Time alignment function allows adjustment in 1-cm steps

When multiple speaker units are used, differences in sound source location (diaphragm position on the front/back plane) will lead to different arrival times of the sound at the listener's ears. Time alignment is a function designed to compensate for such

differences. The DF-45 incorporates this in the form of a DELAY function that electrically adjusts the time when the sound from each driver reaches the listener.

In Figure 3, the sound from the two speaker units [L and R] at the start exhibits a time difference of t seconds due to the front/back distance d (cm) of their respective diaphragms. In order to eliminate this difference, the delay function delays the sound of the (R) unit by t seconds. Normally, a delay would be expressed as a time value, but since the delay here is caused by a spatial distance (of the two diaphragms), the DF-45 converts the delay into a distance value (cm) and shows this value on the display for easier understanding.

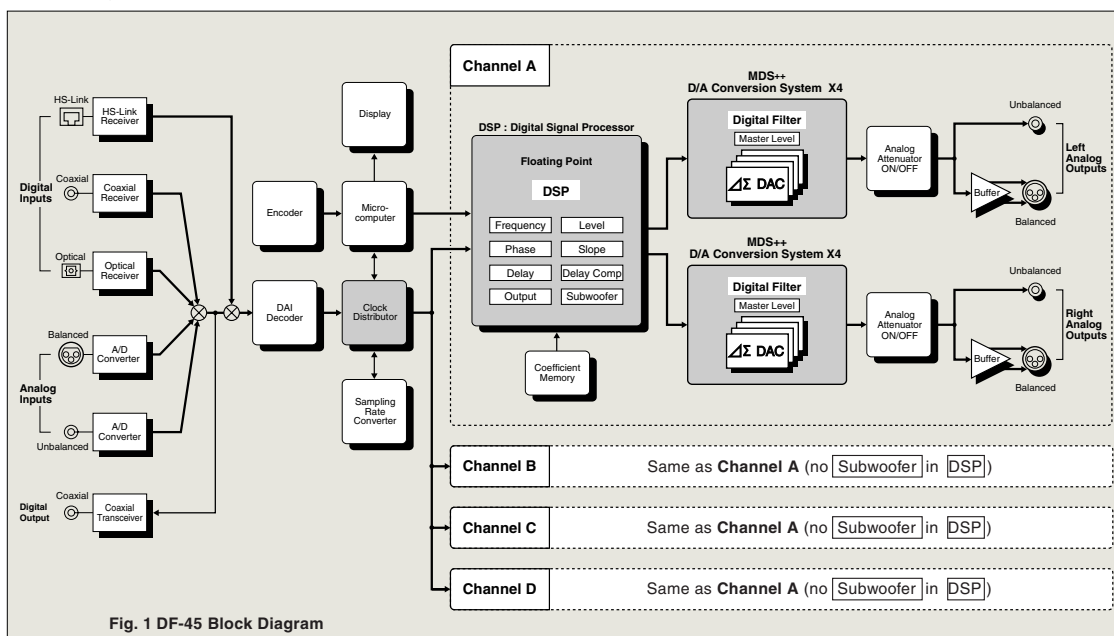

Fig. 1 DF-45 Block Diagram

<Time alignment using delay>

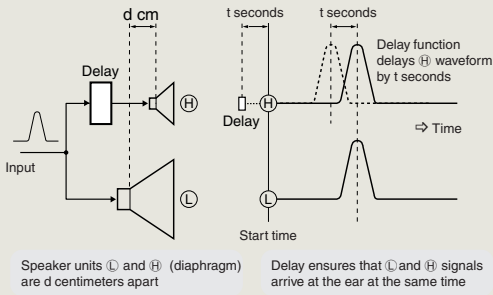

Fig. 3 Principle of time alignment

Speed of sound = $331.5 + 0.607 T$ [ms] T: temperature (°C)
Consequently, at 14°C, sound travels at about 340 m/s.

In the example above, when DELAY function for R is set to d cm, the signal start for R will be delayed by t seconds (*), causing the sound from L and R to reach the listener at the same time.

$$(*) \quad t = \frac{d}{34,000} \text{ (seconds)}$$

Further Improved MDS++ D/A Converter

MDS (Multiple Delta Sigma) is a revolutionary design which employs several delta sigma type converters in a parallel configuration. In the combined output of these multiple converters, conversion errors cancel each other out, resulting in a drastic improvement in all relevant aspects of converter performance, such as accuracy, S/N ratio, dynamic range, linearity, and THD. In the DF-45, four delta sigma type D/A converters (AD1955 from Analog Devices) are driven in parallel. Compared to a single converter, this results in an overall performance improvement by a factor of 2 ($= \sqrt{4}$).



As shown in the diagram, the MDS++ features an enhanced current-to-voltage (I/V) converter for processing the D/A converter output current. To reduce the load on the current adder, a combination of current

summing and voltage summing is used.

The overall result is further improved stability and top-notch performance. The music emerges from a totally silent background, with breathtaking detail resolution and accurate spatial information.

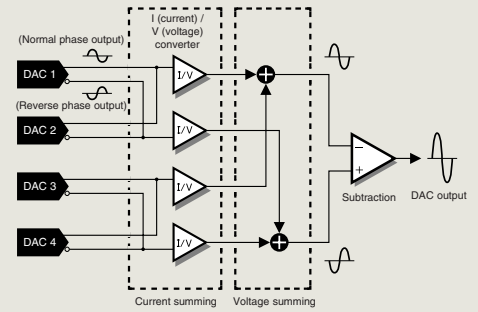

Block diagram of MDS++ converter

Other Functions and Features

- Individual output ON/OFF control for each channel.
- Individual 4-position phase control for each channel.
- Digital attenuator with setting range from -40.0 dB to +12.0 dB (in 0.1-dB steps) allows precise level adjustments for left and right channel.
- Memory for five sets of parameter and function settings in each channel.
- Unused channels can be set to OFF (all display elements and LED indicators are out).
- Safety Lock prevents inadvertently changing any settings.
- "Full Level Output Protection" function safeguards the speakers if a digital signal without volume control data is input (output level is reduced by 40.0 dB).
- Versatile input connector array comprises coaxial, optical and HS-Link inputs for digital signals and balanced and unbalanced inputs for analog signals.
- 5-way and higher configurations can be realized by using more than one DF-45 unit.
- "Analog ATT" function (-10 dB) can be activated for specific channels to reduce residual noise when using high-efficiency midrange or high range speaker units.
- Display indication can show predefined strings or custom strings entered by the user (max. 8 characters, character set with 97 characters).
- Easy selection of Subwoofer (3D) mode using dedicated switch in channel A.
- Analog output for each channel supports balanced connection.

- The DF-45 incorporates four units named CHANNEL A - D (4-way configuration). The assembly shown here carries the coaxial digital input and output connectors, unbalanced analog input connectors, MDS++ D/A converter modules for 4 channels, and unbalanced analog output connectors.

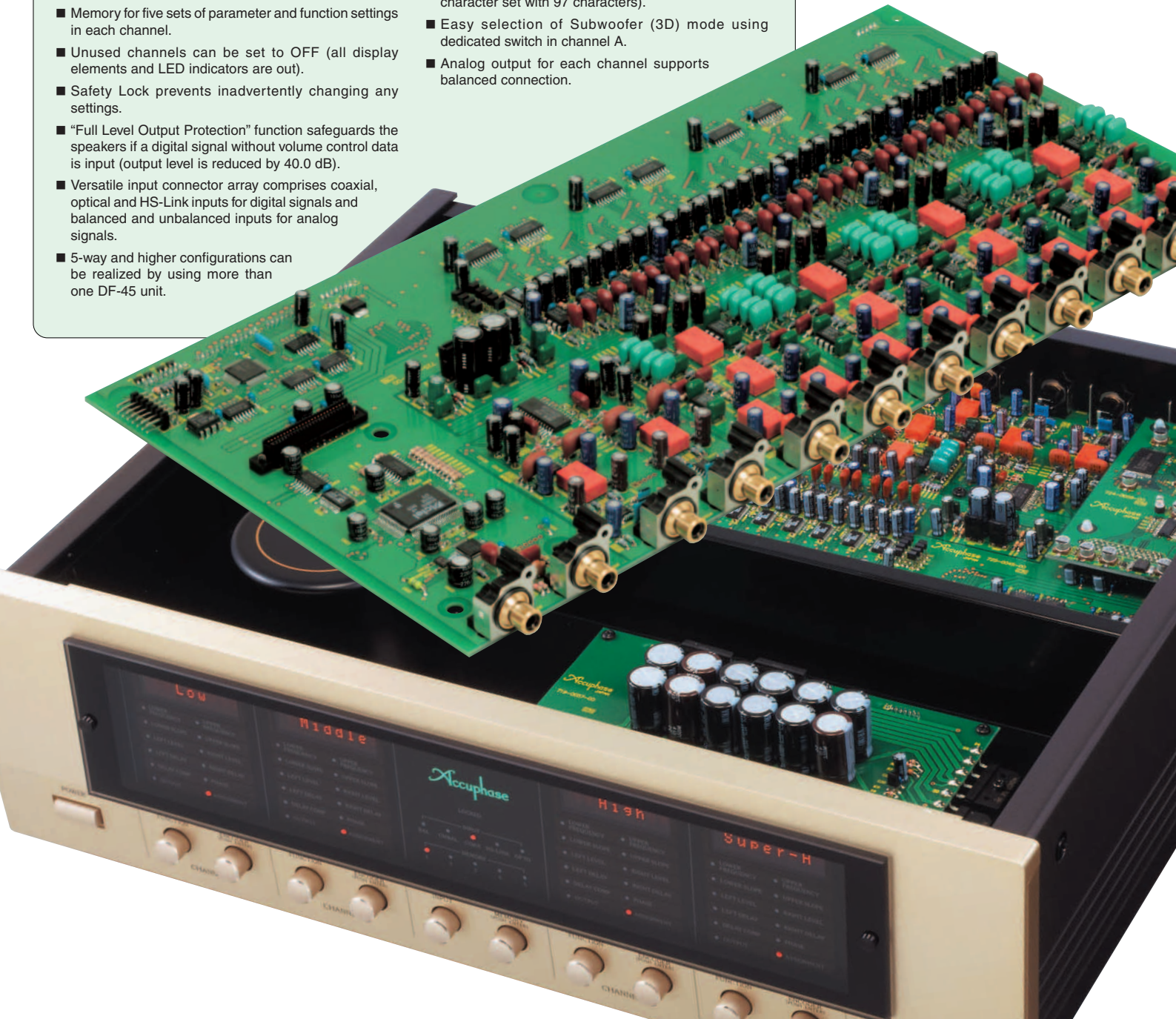

Delay Compensator Function of DF-45 (providing automatic compensation for signal delays)

When a signal passes through a filter circuit, a certain delay will necessarily occur. The DF-45 incorporates a function called "DELAY COMP" that compensates for such delays. As an example, the illustration at right shows how the delay compensator function works in a 3-way system. This is not a representation of the actual circuit, but rather a simplified representation of the operating principle.

■ Regardless of whether a circuit is analog or digital, when the signal has to pass through a filter, the output will be delayed by a certain amount, causing a delay in step response and impulse response.

■ Generally, a low-pass filter will have more delay. The DF-45 therefore only provides compensation when low-pass filtering is used.

■ The lower the filter frequency and the steeper the filter slope, the longer the delay.

ON: The DF-45 calculates and displays the theoretical delay time, and automatically provides compensation. (Default setting)

OFF: The DF-45 calculates and displays the theoretical delay time for reference, and the user can manually set any desired value.

<Operation principle of delay compensator in DF-45>

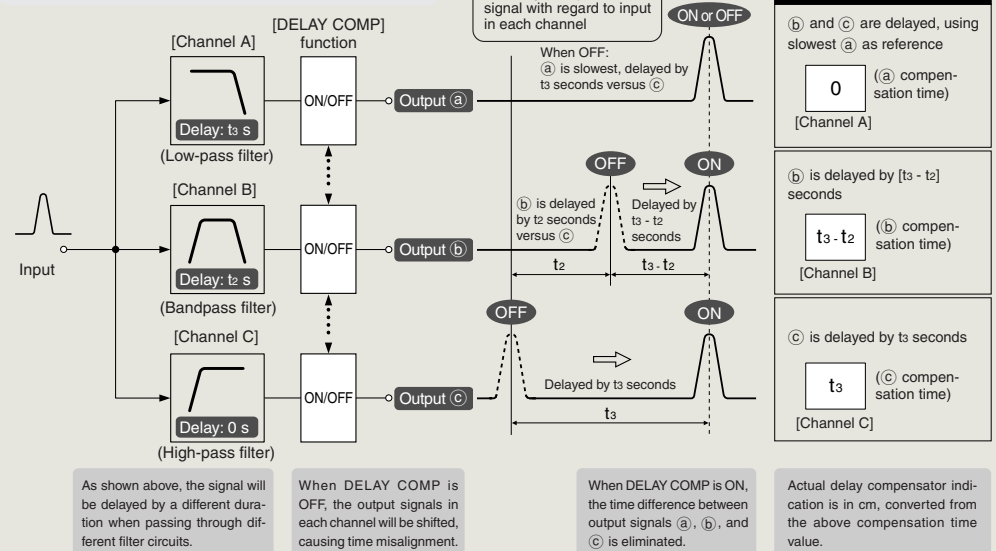

DF-45 default settings and display indication

Function		Display indication	
LOWER FREQUENCY	UPPER FREQUENCY	7100Hz	Pass
LOWER SLOPE	UPPER SLOPE	12dB/oct	---
LEFT LEVEL	RIGHT LEVEL	-40.0dB	-40.0dB
LEFT DELAY	RIGHT DELAY	0cm	0cm
DELAY COMP	PHASE	On: 0	Nor Nor
OUTPUT	ASSIGNMENT	On	Super-H

● (●) symbol at top right of level indication is shown when "Full Level Output Protection" function is set to ON.

Front panel

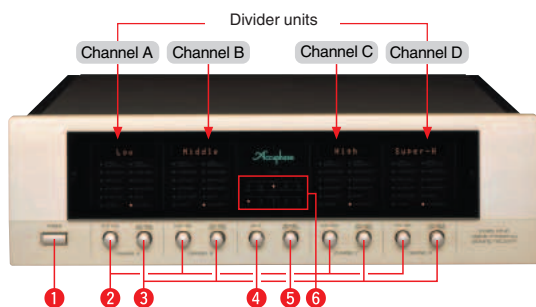

Rear panel

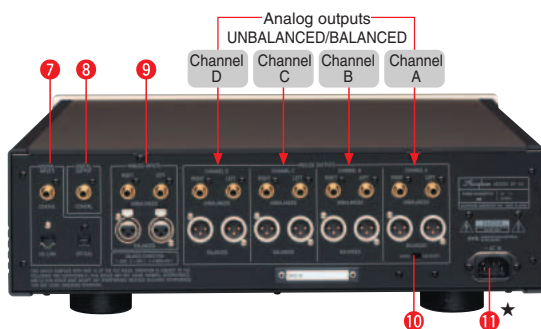

- 1 POWER switch
- 2 FUNCTION knob
- 3 ENCODER knob
- 4 Input selector
- 5 Memory selector
- 6 Display
- INPUT: BAL, UNBAL, COAX, HS-LINK, OPTO MEMORY: 1, 2, 3, 4, 5
- 7 Digital inputs COAXIAL OPTICAL HS-LINK
- 8 Digital output COAXIAL
- 9 Analog inputs UNBALANCED BALANCED
- 10 Subwoofer output selector
- 11 AC power connector (for supplied power cord)★

Remarks

★ This product is available in versions for 120/230 V AC. Make sure that the voltage shown on the rear panel matches the AC line voltage in your area.

★ The shape of the AC inlet and plug of the supplied power cord depends on the voltage rating and destination country.

■ Supplied accessories: • AC power cord

Cutoff frequency settings (Hz)

10	20	31.5	35.5	40	45	50	56	63	71
80	90	100	112	125	140	160	180	200	224
250	280	290	315	355	400	500	560	630	710
800	900	1000	1120	1250	1400	1600	1800	2000	2240
2500	2800	3150	3550	4000	5000	5600	6300	7100	8000
9000	10k	11.2k	12.5k	14k	16k	18k	20k	22.4k	

Guaranteed Specifications

[Guaranteed characteristics measured in compliance with JEITA standard method CP-2402]

Digital inputs

- COAXIAL format: JEITA CP-1201/AES3 compliant
- OPTICAL format: JEITA CP-1201 compliant
- Sampling frequencies: 32 kHz, 44.1 kHz, 48 kHz, 88.2 kHz, 96 kHz (16 - 24-bit 2-channel PCM)
- HS-Link RJ-45 type connector (dedicated cable)
- Sampling frequencies: 176.4 kHz, 192 kHz (24-bit 2-channel PCM)

Digital output

- COAXIAL Format: JEITA CP-1201 compliant
- Level: 0.5 Vp-p, 75 ohms

Frequency response

- 2.0 - 44,000 Hz +0 -3 dB

D/A converter

- 24-bit MDS++ type

THD

- 0.001% (20 - 20,000 Hz)

S/N ratio

- COAXIAL/OPTICAL 114 dB
- HS-Link 116 dB
- Analog input 112 dB

Dynamic range

- "Analog ATT" OFF: 112 dB
- "Analog ATT" ON: 109 dB

Channel separation

- 108 dB (20 - 20,000 Hz)

Cutoff frequencies

- 59 points

Slope characteristics

- 6 dB/octave, 12 dB/octave, 18 dB/octave
- 24 dB/octave, 48 dB/octave, 96 dB/octave

* When cutoff frequency is 10 Hz or 20 Hz, only 6 dB/octave, 12 dB/octave, 18 dB/octave are available.

Delay setting range (converted into distance)

- 0 to 3000 cm (1-cm steps)

Level adjustment range

- "Analog ATT" OFF: -40 to +12.0 dB (0.1-dB steps)
- "Analog ATT" ON: -50 to +2.0 dB (0.1-dB steps)

Output voltage/impedance

- BALANCED: 2.5 V, 50 ohms, balanced XLR connector
- UNBALANCED: 2.5 V, 50 ohms, RCA-type phono connector

Minimum load impedance

- BALANCED: 600 ohms
- UNBALANCED: 600 ohms

Power requirements

- AC 120 V/230 V, 50/60 Hz (Voltage as indicated on rear panel)

Power consumption

- 36 watts

Maximum Dimensions

- Width 465 mm (18-5/16")
- Height 150.6 mm (5-15/16")
- Depth 395.8 mm (15-9/16")

Mass

- 14.1 kg (31.1 lbs) net
- 20.0 kg (44.1 lbs) in shipping carton



• Specifications and design subject to change without notice for improvements.

<http://www.accuphase.com/>

H0505Y PRINTED IN JAPAN 850-0149-00 (AD1)